

Stock List		
NAME	QTY	DESCRIPTION
A	2	$\frac{1}{8}$ x 3 x 5 Stainless Steel
B	2	$\frac{1}{8}$ x 4 $\frac{3}{4}$ x 5 Stainless Steel
C	1	$\frac{1}{4}$ x 3 x 6 Stainless Steel
D	2	$\frac{1}{4}$ NPT Coupling
E	1	$\frac{1}{4}$ NPT Elbow

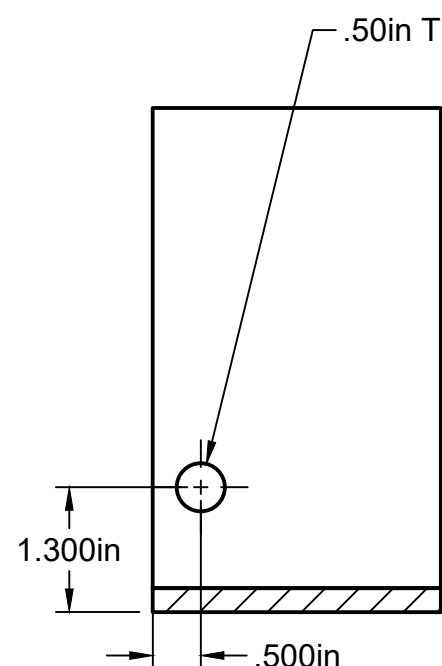

SECTION A-A
SCALE 1:2

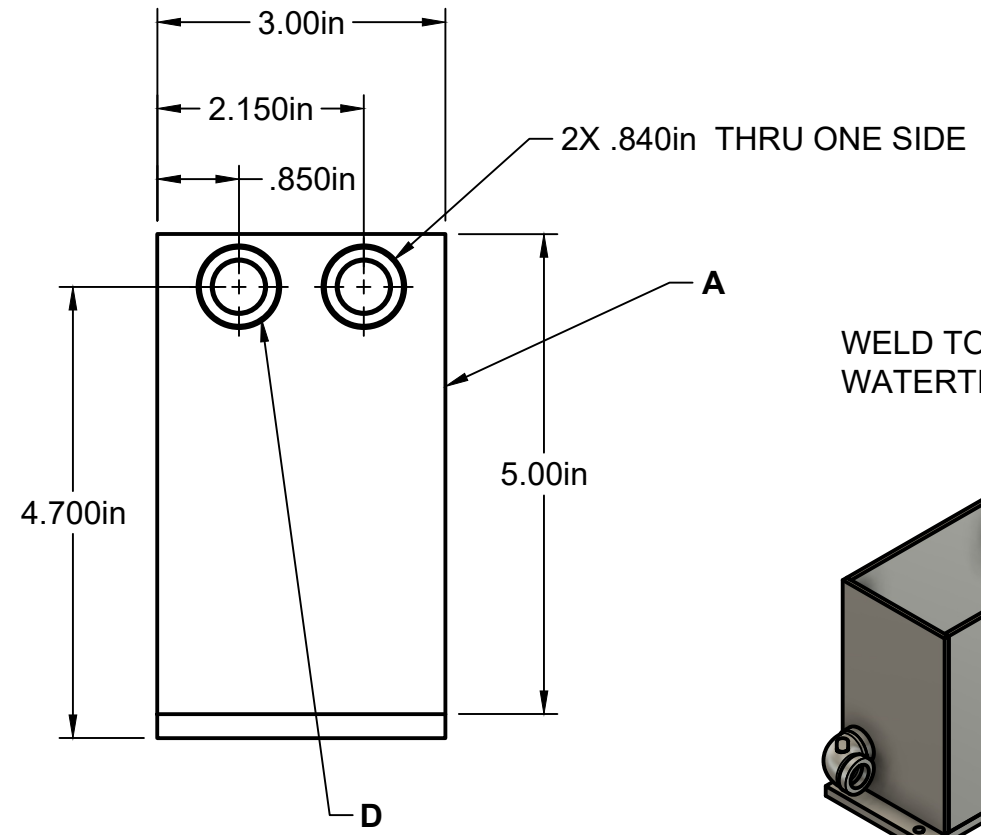
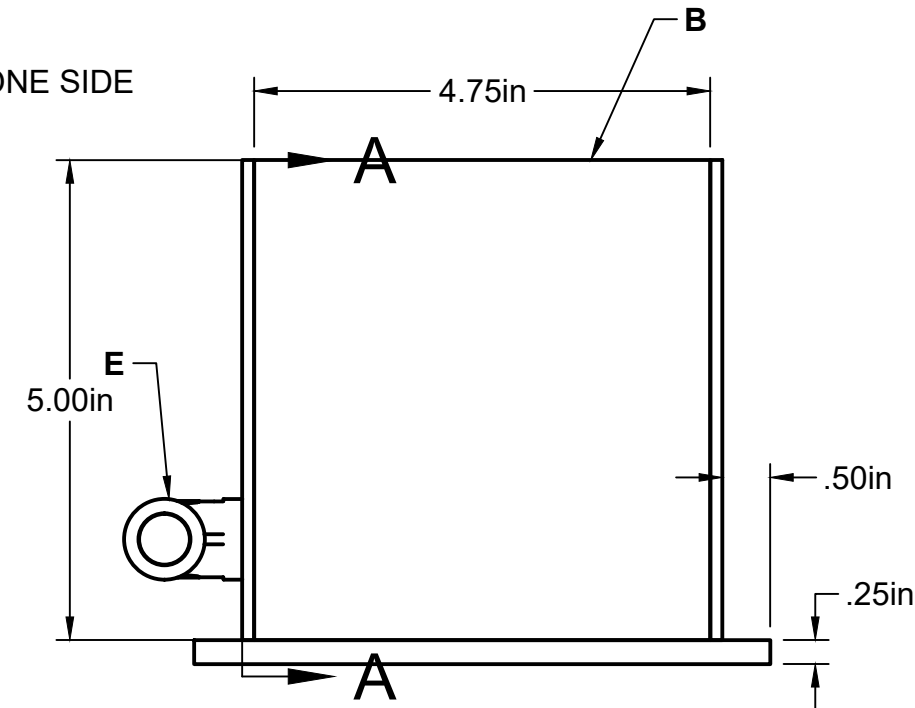

WELD TOGETHER
WATERTIGHT

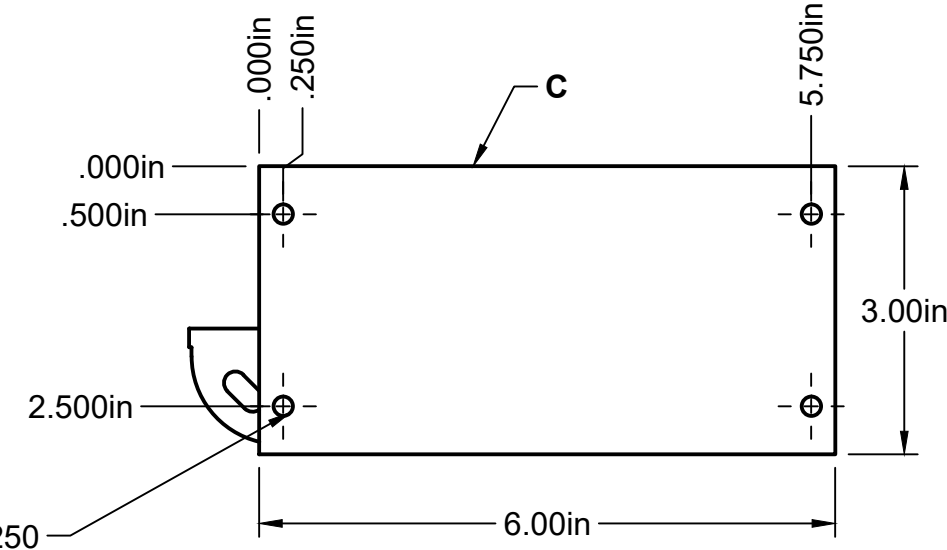
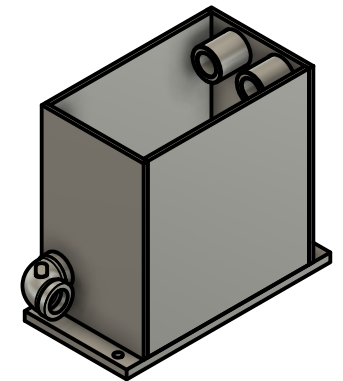

4X \varnothing .2015 ∇ .250
1/4-20 UNC - 2B

TOLERANCES UNLESS SPECIFIED: X.X: ± 0.050 X.XX: ± 0.020 X.XXX: ± 0.005 X.XXXX: ± 0.0005 FRACTIONAL: $\pm \frac{1}{16}$ ANGLE: $\pm 1^\circ$	PROJECT MSD 26236 Solid State Battery		
	TITLE -----		
APPROVED	SIZE B	MATERIAL ----	PART NUMBER A01-S01: Hydraulic Reservoir Assembly
CHECKED			REV 1/28/2026
DRAWN Cullen Straub 1/28/2026	SCALE 1:2 (From parent)	WEIGHT 2080.51 g	SHEET 1/1